

Resilient Seated Solid Wedge Gate Valve - Series 6700

AWWA C509 & C515 ▪ OS&Y Type ▪ FL x FL ▪ Sizes 2" - 16"

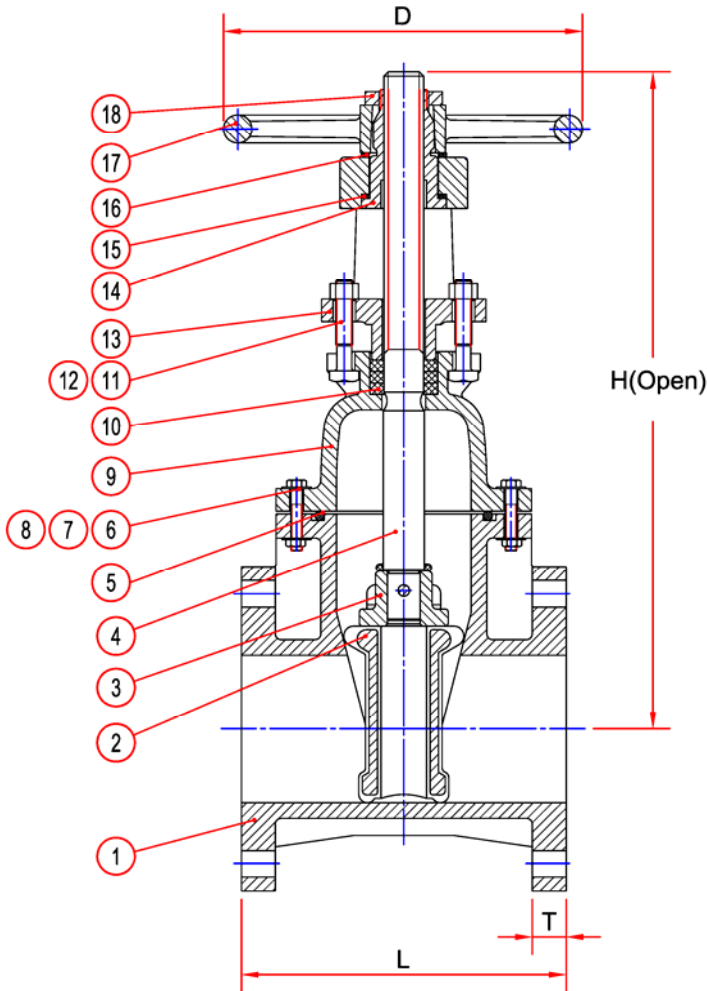

No.	Part Name	Materials
1	Body	Ductile Iron ASTM 536 65-45-12
2	Wedge	Ductile Iron EPDM Encapsulated
3	Stem Nut	Corrosive Resistant
4	Stem	Bronze or Stainless Steel
5	O-Ring Gasket	EPDM
6	Nut	Corrosive Resistant
7	Bolt	Corrosive Resistant
8	Washer	Corrosive Resistant
9	Bonnet	Ductile Iron ASTM 536 65-45-12
10	Packing	Graphite Non Asbestos
11	Nut	Corrosive Resistant
12	Bolt	Corrosive Resistant
13	Gland	Ductile Iron ASTM 536 65-45-12
14	Stem Nut	Bronze ASTM B62 (85-5-5-5)
15	Washer	PTFE Teflon
16	Washer	PTFE Teflon
17	Handwheel	Ductile Iron ASTM 536 65-45-12
18	Handwheel Nut	Chrome Plated Ductile Iron

Features:

- Design and Materials Exceed AWWA C509, C515 & C550.
- Flanges Conform to ANSI B16.1, Class 150.
- Ductile Iron: Body, Bonnet, Wedge, and Gland.
- Fusion Bonded Epoxy Coatings 12 Mils In and Out per AWWA C550.*
- Corrosive Resistant Nuts, Bolts, and Washers.
- Bronze or Stainless Steel Stem.
- Ductile Iron, EPDM Encapsulated Wedge.
- EPDM Gaskets and O-Rings.
- 250 PSI Working Pressure.
- Working Temperature: EPDM 33°F to 248°F.
- Ductile Iron Handwheel or Automatic Actuator Available.

Dimensions:

Size	Model	L	H (Open)	D	T	Approx. Weight
2"	6702	7"	15 ³ / ₄ "	7"	5 ⁵ / ₈ "	51#
2½"	6725	7½"	16"	7"	¾"	59#
3"	6703	8"	19 ¹ / ₈ "	7½"	¾"	68#
4"	6704	9"	24"	10"	1"	105#
5"	6705	10"	27 ¹ / ₂ "	12"	1"	145#
6"	6706	10½"	31 ¹ / ₈ "	12"	1"	172#
8"	6708	11½"	39 ¹ / ₂ "	14"	1 ¹ / ₈ "	243#
10"	6710	13"	46 ³ / ₄ "	16"	1 ¹ / ₄ "	430#
12"	6712	14"	56"	18"	1 ¹ / ₄ "	685#
14"	6714	15"	64"	20"	1 ³ / ₈ "	1,058#
16"	6716	16"	75"	22"	1 ¹ / ₂ "	1,720#