

## Lug Butterfly Valve with Gear & Handwheel - Series 2500GH

150 PSI ▪ Lug ▪ Sizes 14" - 24"

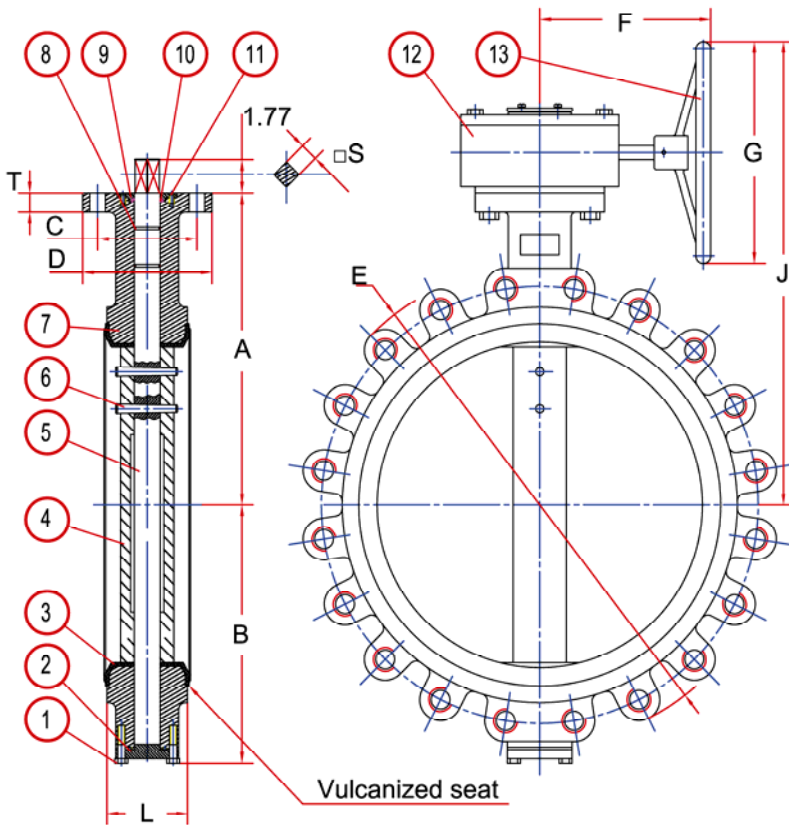

No.	Part Name	Materials
1	Bolt	Carbon Steel
2	O-Ring	EPDM / NBR / Viton
3	Seat	EPDM / NBR / Viton
4	Disc	Stainless Steel Bronze Ductile Iron:Chrome Plated Or FBE Coated
5	Stem	Stainless Steel
6	Pin	Stainless Steel
7	Body	Ductile Iron or Grey Iron
8	O-Ring	EPDM / NBR / Viton
9	Bearing	Teflon
10	O-Ring	EPDM / NBR / Viton
11	Bolt	Carbon Steel
12	Worm Gear Operator	
13	Handwheel	

### Dimensions:

Size	Model	A	B	C	D	E	F	G	J	L	T	S	Approx. Weight
14"	2514GH	14½"	11"	5"	5¾"	20¾"	8¾"	11¾"	22¼"	3"	1"	¾"	179#
16"	2516GH	15¾"	12¼"	5½"	6¾"	23⅝"	10½"	15¼"	26"	3½"	1"	1"	264#
18"	2518GH	16⅝"	13⅜"	5½"	6¾"	26⅞"	10½"	15¼"	26¾"	4¼"	1"	1"	319#
20"	2520GH	18¾"	15¼"	6½"	8¼"	28¾"	9½"	15¼"	28¾"	5"	1"	1¾"	397#
24"	2524GH	22⅝"	17¾"	6½"	8¼"	33"	9½"	15¼"	32"	6"	1⅞"	1¾"	546#