

Lug Butterfly Valve with Gear & Handwheel - Series 2500GH

200 PSI ▪ Lug ▪ Sizes 5" - 12"

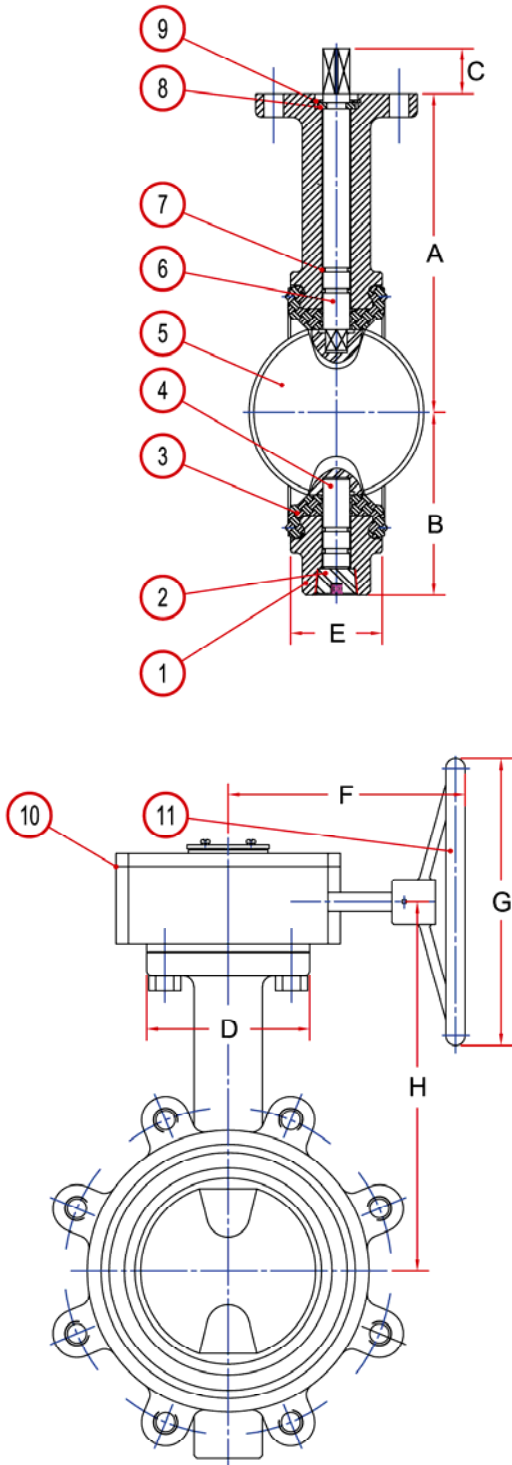

No.	Part Name	Materials
1	Body	Ductile Iron or Grey Iron
2	Plug	Carbon Steel
3	Seat	EPDM / NBR / Viton
4	Lower Shaft	Stainless Steel
5	Disc	Stainless Steel Bronze Ductile Iron:Chrome Plated Or FBE Coated
6	Upper Shaft	Stainless Steel
7	O-Ring	EPDM / NBR / Viton
8	Lock Plate	Bronze
9	Snap Ring	Carbon Steel
10	Worm Gear Operator	
11	Handwheel	

Dimensions:

Size	Model	A	B	C	D	E	F	G	H	Approx Weight
5"	2505GH	8½"	5¼"	1⅛"	3½"	2¼"	6⅓"	7⅝"	8⅞"	33#
6"	2506GH	8⅞"	5½"	1⅛"	3½"	2¼"	6⅓"	7⅝"	9¼"	38#
8"	2508GH	9½"	6⅞"	1⅛"	5"	2⅜"	9⅓"	11⅝"	11¼"	61#
10"	2510GH	11⅝"	7⅞"	1⅛"	5"	2¾"	9⅓"	11⅝"	12½"	79#
12"	2512GH	13¼"	9¼"	1⅛"	5"	3⅜"	9"	11⅝"	14⅓"	105#